

Omega[®]

CE

**Modular
Enlarger
System**

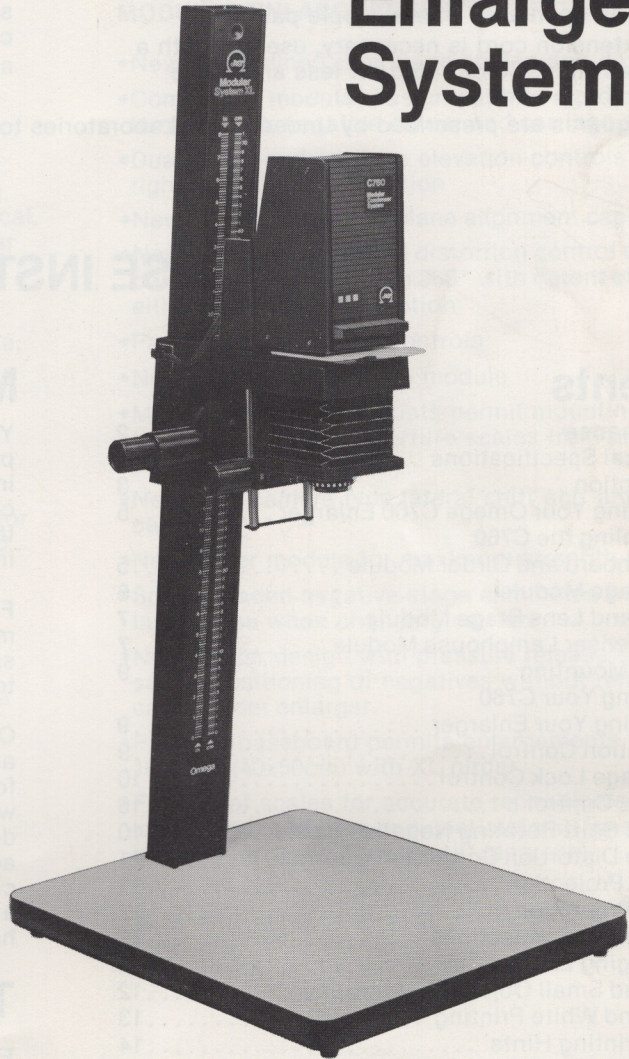

Instruction Manual

Important Safeguards

When using your Omega photographic products, basic safety precautions should always be taken, including the following:

1. Read and understand all instructions provided with this product.
2. Close supervision is necessary when this product is used by or near children. Do not leave it unattended while it is plugged into an outlet.
3. Avoid touching the lamp area of enlargers or other hot parts as it may cause burns.
4. Do not operate this product if the power supply cord has been damaged or if the product has been dropped or damaged. Have it checked out and repaired, if necessary, by a qualified service person before using.
5. Route the power supply cord away from hot areas. Do not let the cord hang over a counter edge or across an open area where people pass.
6. If an extension cord is necessary, use one with a suitable rating. Cords rated for less amperage than the product may overheat. Route the extension cord away from open areas where it may be tripped over or pulled.
7. Always unplug the product after use. Grasp the plug and firmly pull it from the outlet to disconnect. Never yank the cord from the outlet.
8. Allow the product to cool to room temperature before storing. Wrap the power cord loosely around the product.
9. Do not immerse this product in water or other liquids.
10. To reduce the risk of electric shocks, do not attempt to disassemble or repair this product. Always have it serviced by qualified service personnel when necessary. Incorrect reassembly can cause electric shock hazards.

These safeguards are prescribed by Underwriters Laboratories to be included in this instruction manual for U.L. listed products.

SAVE THESE INSTRUCTIONS

Contents

1. Maintenance	2
1. Technical Specifications	2
3. Introduction	3
4. Unpacking Your Omega C760 Enlarger	5
5. Assembling the C760	
a. Baseboard and Girder Module	5
b. Carriage Module	6
c. Film and Lens Stage Module	7
d. Condenser Lamphouse Module	7
e. Lens Mounting	9
6. Operating Your C760	
a. Aligning Your Enlarger	9
b. Elevation Control	9
c. Carriage Lock Control	10
d. Focus Control	10
e. Rapid Shift Rotating Negative Carrier	10
f. Image Distortion Correction Controls	11
g. Floor Projection	11
h. Wall Projection	12
i. Electrical Connections	12
j. Enlarging Lenses	12
7. Copy and Small Object Photography	12
8. Black and White Printing	13
9. Color Printing Hints	14
10. Recommended Reading	14
11. Omega C760 Accessories	14

Maintenance

Your Omega C760 has been designed to function properly with a minimum of attention. The most important maintenance step is to keep the enlarger clean and dry. Keep a dust cover on your enlarger and the lens cap on your enlarging lens except when it is in use.

For smooth, quiet operation of the elevation control, it may be necessary to lubricate the counterbalance spring periodically. Use a silicon type grease applied to the surface of the counterbalance spring.

Occasionally wipe the focus rods with a clean cloth and alcohol. **Do not**, under any condition, lubricate the focus rods or the focus mechanism. You may also want to dust the front surface of your lens or condensers with a fine camel-hair brush. If you accidentally get fingerprints on the lens or condensers, gently remove them with lens cleaner and a lens tissue. **Do not rub your lens with a handkerchief!**

Technical Specifications

Film Format Range Minox to 35mm to 2 1/4"x2 3/4"
	(6x7cm)
Baseboard Dimensions 18"x22"x1 1/4"
Maximum Height:	
XL 50"
Standard 42"
Condenser Lamphouse:	
Power 120VAC, 50/60 Hz.
	or 230VAC, 50/60 Hz.
Lamp 75W/120V (Cat. No. 471-038)
	or 75W/230V (Cat. No. 471-041)

Introduction

Thank you for selecting the Omega C760 Modular Enlarger System. We are confident that the smooth operation, the versatility and responsiveness of the system, and the sharpness and brilliance of your prints will confirm the wisdom of this selection.

For almost half a century, the name "Omega" has identified the finest enlarging equipment available, designed with the needs of the photographer — amateur or professional — in mind. From the very first models, the emphasis has been on a clean, functional design and superior performance. Over the years, Omega enlargers have been improved to reflect advances in photography, in engineering and in optics. However, every model has been developed to meet one continuing goal — to provide the photographer with the most reliable, most functional, most trouble-free tool possible for producing top-quality prints.

This goal has been carried forward with your Omega C760. Conceived as a completely new enlarger, the C760 was created to meet the needs of today's photographers for a high-quality, high-performance unit capable of handling virtually every requirement. Particular attention was paid to human engineering, with all components and controls designed for logical, convenient operation. This permits the photographer to concentrate on the print, not on trying to master the equipment.

The Omega C760 uses a modular concept for simple, easy assembly and disassembly. In addition, the modular design permits interchangeability of components to meet changing demands.

This manual goes beyond the usual instruction manual to provide a concise outline of printing with the C760 System. Thus, in addition to instructions for setting up and operating your enlarger, you will find information to help you with color and black and white printing.

And, as always, please feel free to contact Omega if you have any questions or problems. Simply drop a line, with full details of your problem and the Omega equipment you are using to: Customer Service.

In U.S.A.

Berkey Marketing Companies
25-20 Brooklyn-Queens Expressway West
Woodside, NY 11377-7893

or

Berkey Marketing Companies
3400 East 70th Street
Long Beach, CA 90805

In Canada:

Berkey Photo (Canada) Ltd.
70 Floral Parkway
Toronto, Canada M6L2C1

In Denmark:

Berkey Technical A/S Denmark
160 Vangedevej
2860 Soeborg
Copenhagen, Denmark
(Copenhagen) 69 61 11

FEATURES OF THE OMEGA C760 MODULAR ENLARGING SYSTEM

- New streamlined space age styling and design
- Completely modular design permits rapid changes of lamphouses, negative carrier and carriage assemblies
- Dual focus and carriage elevation controls permit right or left hand operation
- New ultra precise dual plane alignment capability
- New wall projection and distortion control capability permits rotation of up to 360° with detent every 90° in either left or right projection
- Fast, positive locking controls
- New film and lens stage module
- Multi-position lens mounts permit mounting lenses for easy viewing of aperture scales from any working position
- New view camera type lateral shift and angular tilt capability
- New girder module for maximum strength and rigidity
- Spring loaded negative stage eliminates need to lift lamphouse when changing carriers
- New carrier design with pressure release slide for safe repositioning of negatives without removing carrier from enlarger.
- Full size baseboard permits enlargements up to 16"x20" (40x50cm) with XL girder
- Full set of scales for accurate repositioning: height (calibrated in inches and centimeters), lens shift (centimeters) and carriage tilt (degrees)

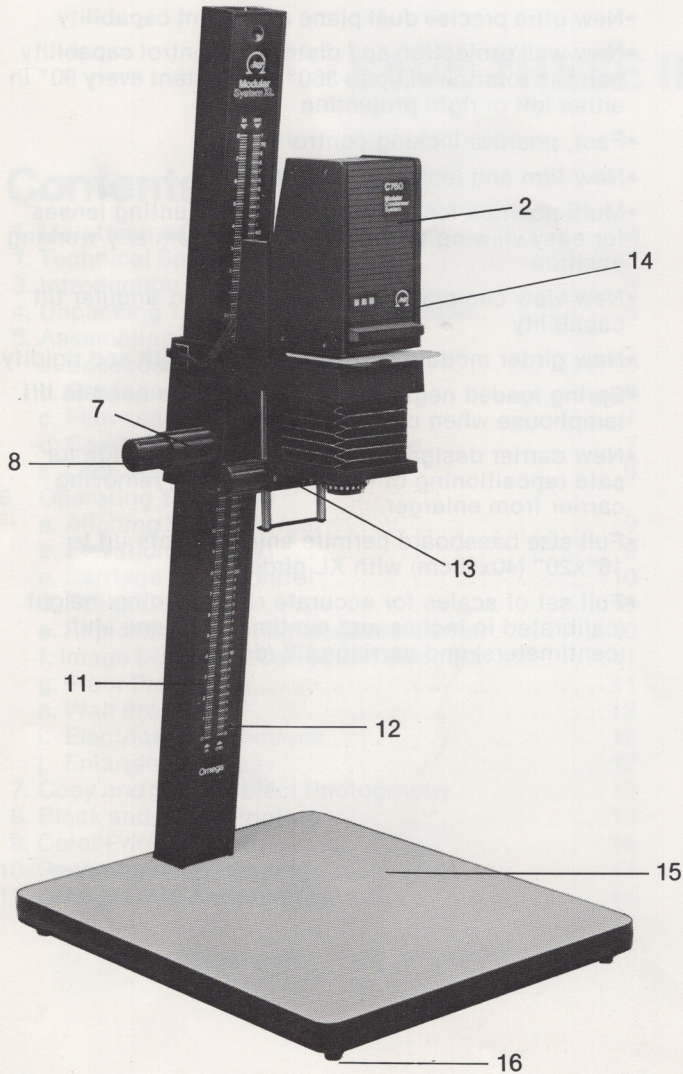
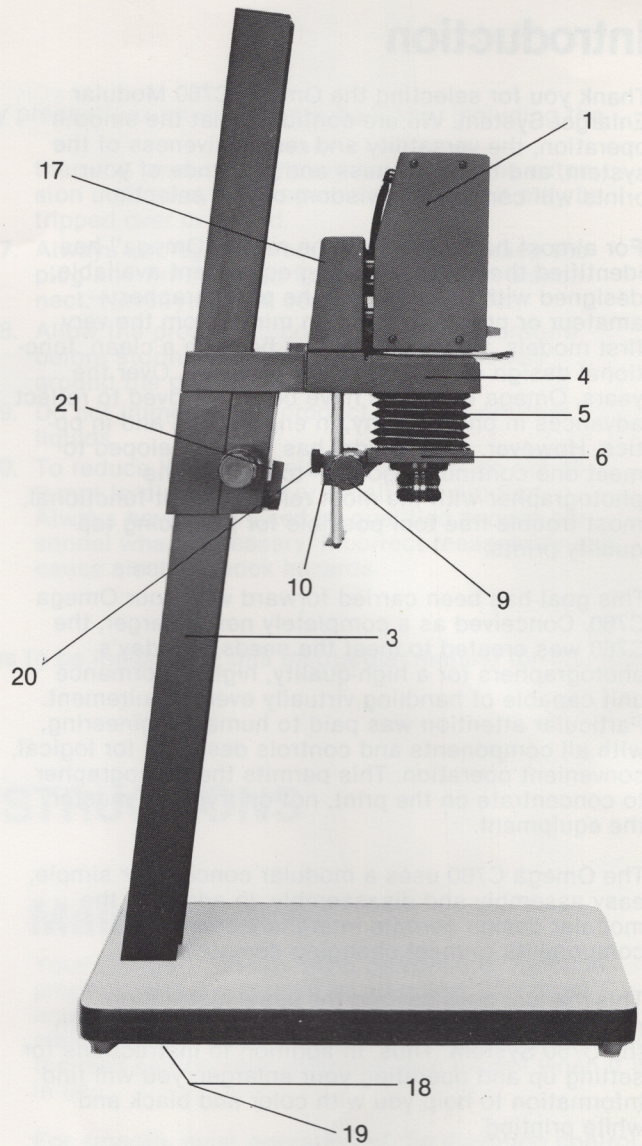
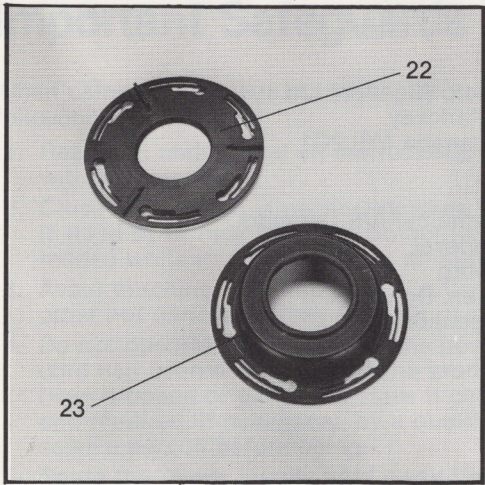

Omega C760 Enlarger

1. Condenser Lamphouse
2. Access Door
3. Girder
4. Film Stage
5. Bellows
6. Lens Stage
7. Fast Elevation Control
8. Fine Elevation Control
9. Focus Control
10. Friction Adjustment Controls
11. Inch Reference Scale
12. Centimeter Reference Scale
13. Centimeter Reference Scale for Lateral Shift of Lens Stage
14. Film/Lens Stage Locking Knob
15. Baseboard
16. Baseboard Feet
17. Lamphouse Locking Screws
18. Stabilizing Plate
19. Girder Mounting Nuts
20. Lens Stage Locking Knob
21. Carriage Lock Control
22. Flat Lensmount
23. Recessed/Extended Lensmount

Unpacking Your Enlarger

Your Omega C760 Enlarger is packaged in one of two ways, depending on how it was purchased. If the enlarger was purchased complete with lens kit, you will find the enlarging lens, negative carrier of appropriate size, and dust cover packed with your unit. If you ordered the C760 Enlarger without the lens kit, you will find all the components *except* lens, negative carrier and dust cover.

Your basic package should contain:

1. Baseboard
2. Lamphouse Module in its own carton (Condenser, Diffusion or Dichroic) as specified on the label of the shipping carton
3. Carriage Module
4. Girder (Standard or XL Model, as specified on the label)
5. Two lens mounts, one flat and one recessed/extended
6. Stabilizing plate with four nuts
7. Special wrench for tightening nuts
8. Power Cord retainer (with adhesive backing)
9. Wrench retainer (with adhesive backing)
10. Four rubber feet for insertion into baseboard
11. Four lamphouse locking knobs

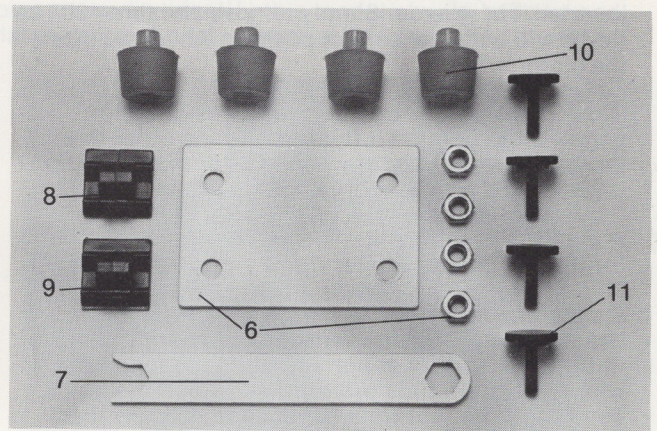

If you order a special lens kit, you will also find:

1. Enlarging Lens (50mm or 75mm focal length, as ordered)
2. Negative Carrier (for 35mm negatives or slides with the 50mm lens, for 2¼" x 2¼" [6x6cm] negatives with 75mm lens)
3. Dust Cover

Additional negative carriers for other formats are available as accessory items. For details, see page 14.

Be sure to unpack your enlarger very carefully and examine all packing materials before discarding them to make sure that nothing has been left in the package accidentally. Use the "check off" list supplied.

Assembling Your Enlarger

Before unpacking your enlarger and starting to assemble it, clear an adequate working area, preferably the top of a desk or sturdy table, to provide ample working space at a comfortable height. Assembly is not difficult or time consuming but it should be done with reasonable care. Before you begin the actual assembly, familiarize yourself with the various components and parts of the Omega C760 System. All modules have been designed to fit together easily and smoothly. **DON'T FORCE ANYTHING:** if you have a problem, check the applicable section of this instruction manual.

Baseboard and Girder Modules

1. Take the four rubber feet and insert them into the holes at each corner of the baseboard. The feet go into the bottom of the baseboard: the white side is your working surface when using the C760 enlarger.
2. The feet should be inserted as far as they will go. A gentle turning motion will make correct insertion easier. When all four feet are properly installed, the baseboard should be level with all four feet in perfect contact with the table or desk top.
3. Move the baseboard to an edge of the table or desk so that the four holes for the girder studs extend beyond the edge to permit access to the bottom of the baseboard.

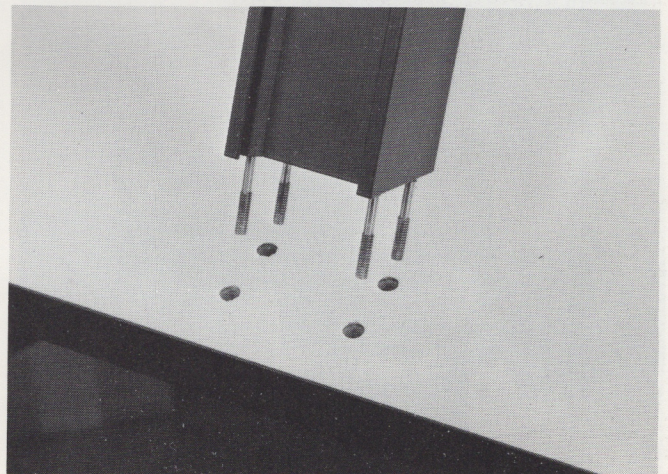

4. Take the girder of the C760 which has four studs securely mounted at the bottom. Insert these studs into the corresponding holes in the baseboard. The C760 uses an inclined girder so that when it is properly inserted, the girder will lean toward the opposite end of the baseboard. If the girder inclines away from the baseboard — you have inserted it in reverse. Simply remove and turn 180° so that it will be in the correct position when you insert the girder.

(Note: The reversible feature was designed to permit projection on a floor or surface other than the enlarger baseboard when greater magnification is required. See page 11 for further information.)

5. A metal stabilizing plate is used to provide support for the girder and greater rigidity for the enlarger. This plate, with four holes drilled to accept the studs from the girder, is placed *under* the baseboard. Slide the plate over the studs until it rests flat against the lower surface of the baseboard with the girder studs protruding through the holes. Then, take the four nuts supplied and screw them over the studs to keep the stabilizing plate in position.

(Caution: Be sure girder is fully seated on baseboard before releasing it to secure stabilizing plate.)

First, tighten the nuts by finger pressure until they are securely fastened to the studs. Then, take the special wrench (which you will find packed with your enlarger) and place the closed end over the nuts and tighten until the entire assembly — girder, baseboard and mounting plate — is rigid and secure. It is important to tighten the nuts as much as possible, exerting as much force as you can, for optimum rigidity.

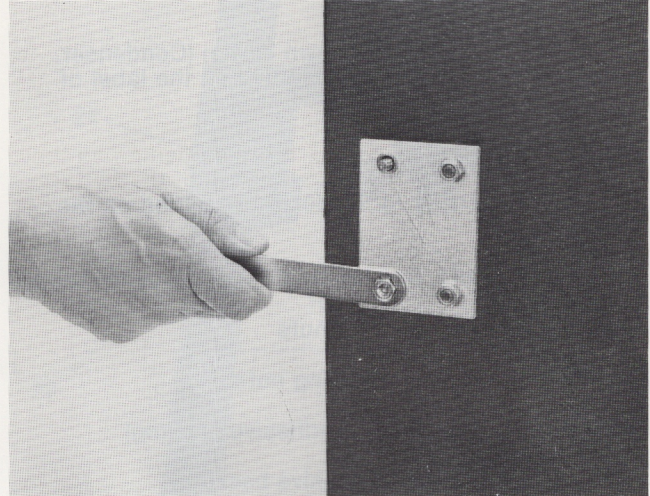

Carriage Module

Once the baseboard and girder modules are assembled and securely bolted to form a single, strong, rigid assembly, the next step is to mount the carriage module. This module, identified by the two sets of elevating knobs on either side, contains the counterbalance spring enclosed within the housing.

1. Take the carriage module and check the locking lever, located at the front of the module between the elevating knobs. This lever should be in the horizontal (unlocked) position before trying to mount the carriage module on the girder. If the lever is in the vertical (locked) position, rotate it to horizontal position, otherwise, the carriage module will not fit over the top of the girder.
2. Hold the carriage module by the hand grips with the chrome plate at the rear facing you. You will be able to see part of the two guide wheels. Stand behind the girder and lift the carriage module over the top of the girder, then bring it down over the girder so that the two wheels fit into the grooved tracks on either side of the girder.

3. At this stage, the carriage module is resting on the top of the girder. To lower it into operating position, simply twist the large handles forward and the carriage module will slip over the top of the girder, sliding down and traveling in the grooves. Pull the carriage module down to a convenient height, then release the elevation knobs to lock the module into place. As you lower the carriage module, you will feel some resistance from the counterbalance. This is normal.

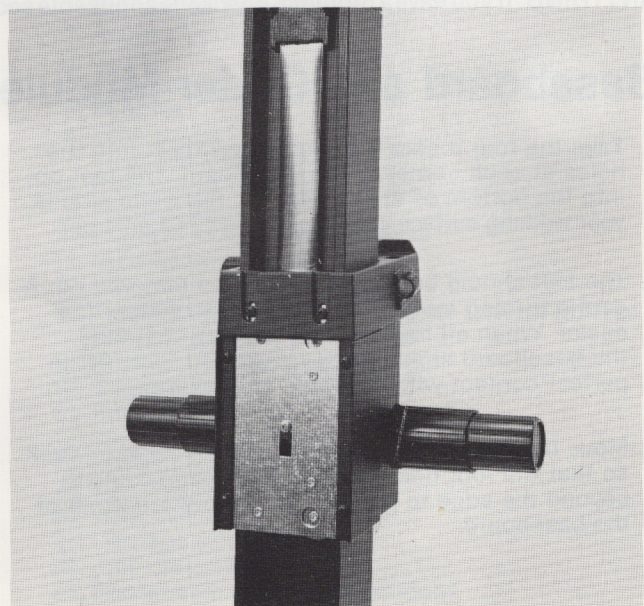
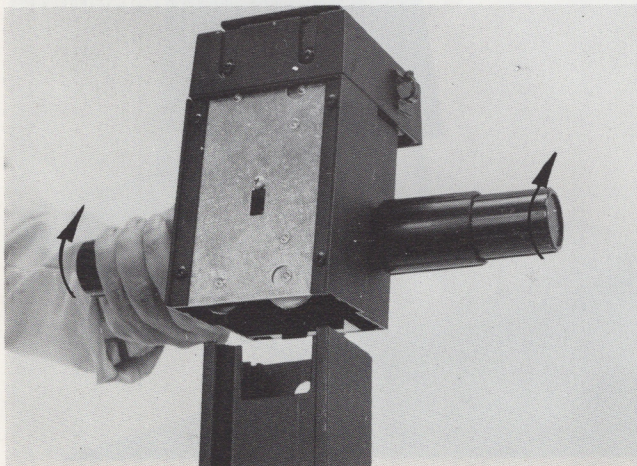

- Once the carriage module is positioned at a convenient height, lock the carriage by moving the carriage locking knob from the horizontal to the

vertical position. Then turn the enlarger so that you are in front of the unit. All other modules can be mounted from the front.

Film and Lens Stage Module

The next step is to mount the film and lens stage module. You can readily identify this module by its bellows and twin focusing rods. At the rear of the module you will find a large grooved post permanently fixed in the center of the mounting plate.

- Before securing this module in place, unscrew the film and lens stage mounting knob so that it is not visible in the opening.
- The grooved post is inserted into the opening on the carriage module and pressed home until the two modules are in contact. You will know that the film and lens stage module is positioned correctly when you feel the detent on the module engage the spring on the carriage module.
- Once the film and lens stage module is in position, tighten the mounting knob until the film and lens stage module is securely locked into position.

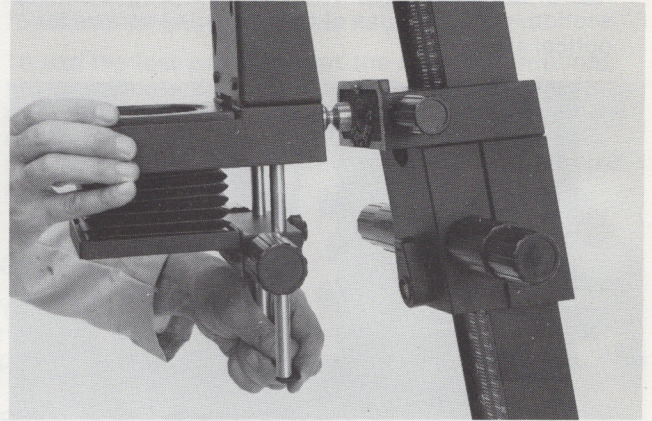

Condenser Lamphouse Module

The Condenser Lamphouse Module is one of three lamphouse options available for the C760 Enlarger, the other two being a Diffusion Lamphouse (for black and white printing) and a Dichroic Lamphouse (for color and black and white printing). All three units mount in similar fashion on the Film and Lens Stage Module. This section covers the installation and use of the Condenser Lamphouse. For information on mounting and using the Diffusion and Dichroic Lamphouses, consult the special instructions packaged with these units:

- The C760 Condenser Lamphouse is packaged as a unit in a separate container. You will find:
 - Two matched standard condenser lenses (for medium format enlarging using 75mm to 105mm focal length lenses);
 - A thinner condenser lens (for enlarging 35mm and smaller formats using lenses with focal lengths of 50mm or less);
 - Special teardrop enlarger lamp (mounted in the lamphouse);
 - Three black glides and Phillips head screws.

- At the rear of the lamphouse are three holes, two on one side and one on the other side. These holes are for attaching the black grooved glides. There are three Phillips head screws used to attach the glides to the lamphouse, using a Phillips head screwdriver. Place the screws into the glides with the grooved end closest to the head of the screw. Screw each glide into place at the rear of the lamphouse. Tighten the screws to make sure the glides are securely fastened to the lamphouse.

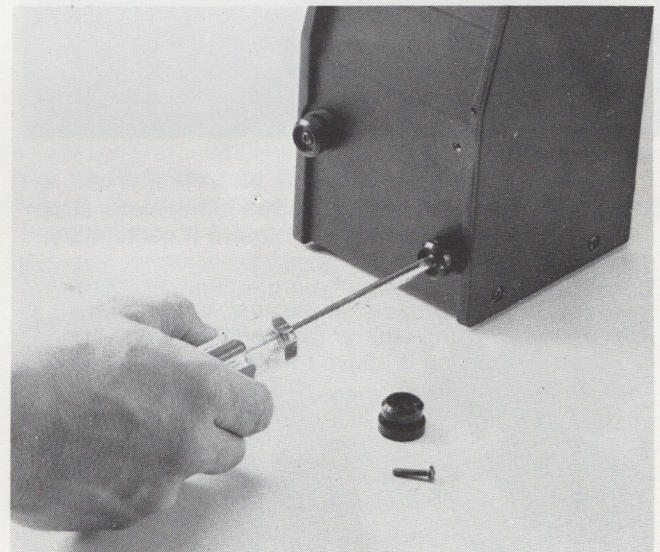
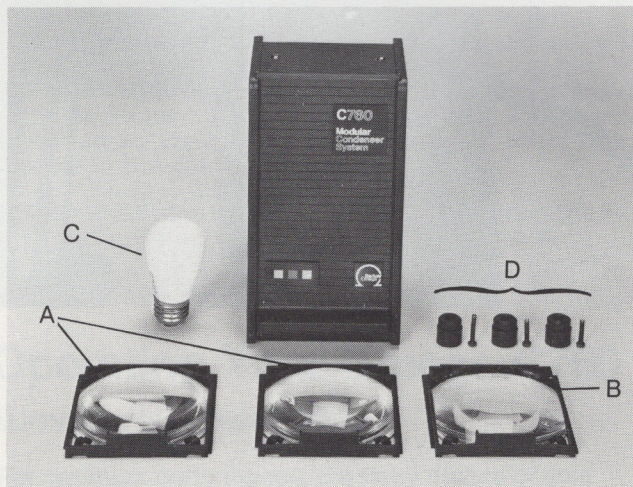

3. Mount the four knurled locking screws onto the lamphouse mounting plate from the rear, making sure not to extend them beyond the mounting plate.
4. Place the lamphouse on the Film and Lens Stage Module so that the glides fit into the corresponding key shaped openings on the mounting plate. When the lamphouse is in position, tighten the knurled locking screws until they make contact with the rear of the lamphouse. Note: Refer to alignment section, page 9 for use of these knurled screws for optical alignment.

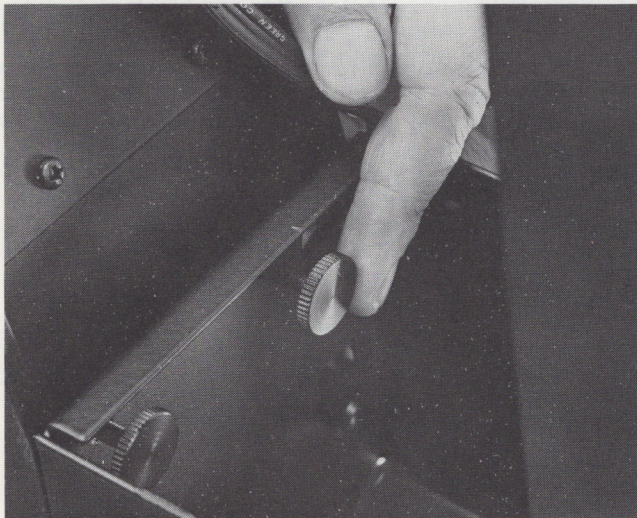
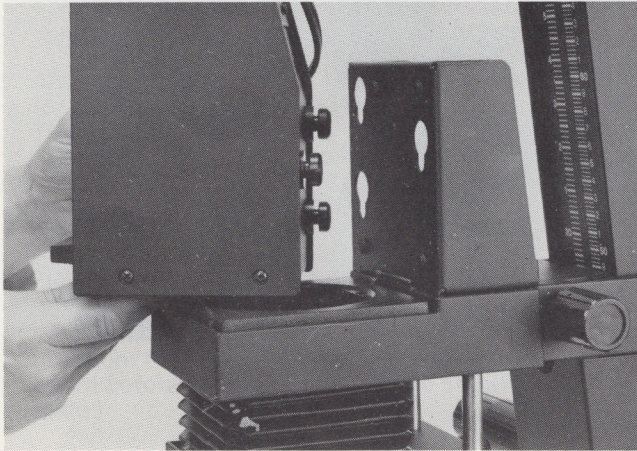

5. To insert the condensers into the lamphouse, slide the lamphouse cover up and remove it completely.

If you are using a 75mm enlarging lens or more, use the matched thick condensers. If you are using a 50mm enlarging lens or less, add the smaller condenser by placing it above the two large ones in

the proper slot so that the curved surface faces the enlarging lamp. Refer to illustration on rear of lamphouse access door for proper placement.

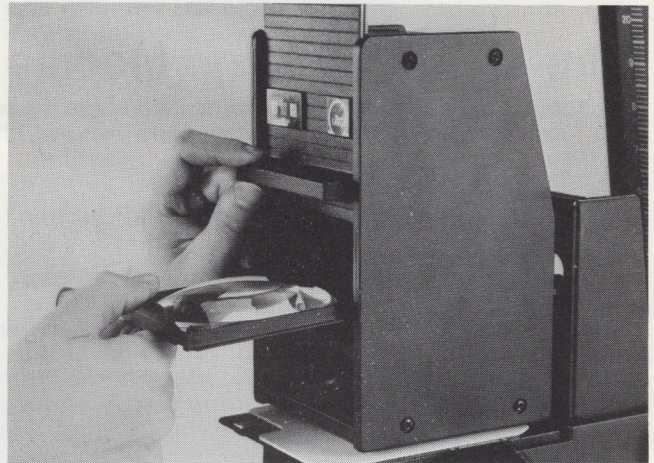

6. Available as optional accessories for the Condenser Lamphouse are a Heat Absorbing Glass (Cat. No. 473-118) and a Filter Drawer (Cat. No. 429-037) which provide facilities for using 75mm x 75mm filters for color printing or for variable contrast black and white printing. The use of a heat absorbing glass is strongly advised when using filters to prevent fading and heat damage. Refer to diagram on back of lamphouse cover for proper placement of these accessory items.
7. When the condensers are completely placed, replace the condenser lamphouse cover and bring the power cord around to the front of the enlarger. Remove the backing from the power cord retainer and mount the retainer at either side of the carriage module pressing firmly with the spring clamp upward. Then, slip the power cord into the retainer. This will keep the cord out of the way when the enlarger is in use.

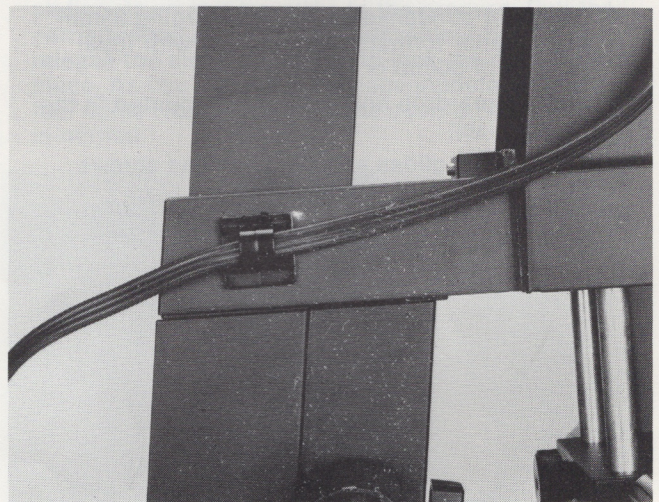

Lens Mounting

1. The multi-position lens mounts supplied with the C760 Enlarger accept any enlarging lens with a 39mm Leica thread.
2. Screw the lens into the lens mount. You will notice a series of slots and thumb rests on the front of the mount. This is for positioning and mounting the lens on the lens stage.
3. The lens mounts are designed to provide a choice of positions when the lens is mounted on the enlarger. You should mount your lens so that you can see the aperture scale easily from whichever position you favor when enlarging — left or right side or in front. If you cannot see the lens aperture scale, just remove the lens mount and use another slot for mounting to bring the lens into the desired position.

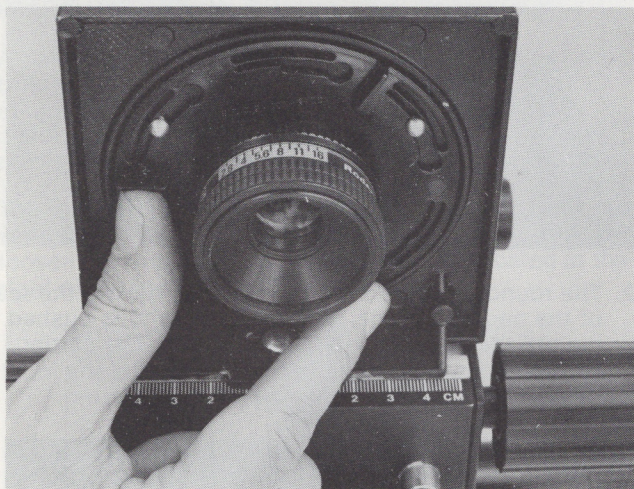

4. The lens stage has three locating posts. Position the slots in the mounts over the post and give it a slight twist clockwise so that the mount snaps into position.
5. If your lens is supplied with a lock ring, remove it before placing the lens into the lens mount.
6. If you are using a lens shorter than 50mm (28mm or 35mm for enlarging Minox and 110 negatives) or El-Omegar 50mm lenses, use the recessed/extended lens mount. Screw the lens into the lens mount in the "recessed" position, then place the lens mount on the enlarger lens stage and secure. Most other 50mm lenses can be mounted on the flat lens mount. Due to the varied back focal distances of 50mm lenses, some will require the use of the recessed lens mount in place of the flat lensmount.
7. The recessed/extended lens mount is used in the extended position for increased reduction ratios.

Operating Your Omega C760

ALIGNING YOUR ENLARGER

For optimum performance, the three stages of your enlarger — negative carrier, lens mount, and

baseboard — should be perfectly parallel. Your Omega C760 Enlarger is designed to provide the rigidity and parallelism you need. However, to ensure the highest quality results, you should check the alignment of your enlarger when you first assemble the modules and whenever you change lamphouses.

To provide accurate alignment checks, Omega supplies a special 35mm negative test pattern with alignment instructions. This negative is used with the 50mm lens. A 2¼"x2¼" test negative for use with 75-105mm lenses is available as an accessory.

To use the test pattern insert the negative strip into the appropriate carrier. Insert the carrier into the enlarger, set your lens to its largest opening, turn the enlarger lamp on, focus and compose to an 8"x10" size. Follow the alignment instructions shown on the test pattern.

CONTROLS

Your Omega C760 Enlarger features dual (left and/or right hand) controls for focusing and elevation to permit convenient operation from any position.

ELEVATION CONTROL

Elevation, which controls the degree of magnification, is controlled by dual concentric knobs on either side of the carriage module. The inner (larger) knob is spring loaded and when rotated toward the operator provides for rapid elevation control of the carriage module up or down the girder. To use, simply grasp the knob and turn toward you: this releases the spring lock, and the carriage lock module will travel up and down freely. To stop, release the knob, and the spring lock automatically takes hold.

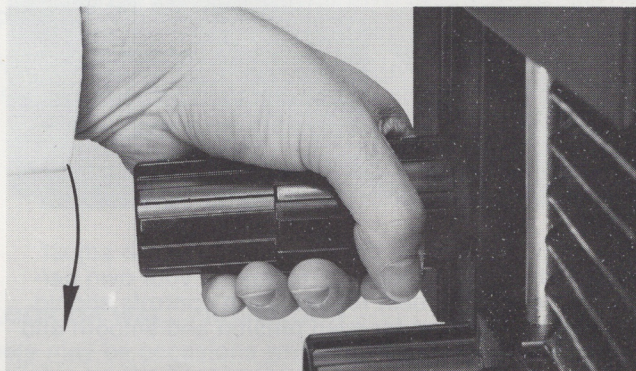

For fine adjustments, turn the smaller (outer) knobs which provide small changes to adjust composition or image size slightly.

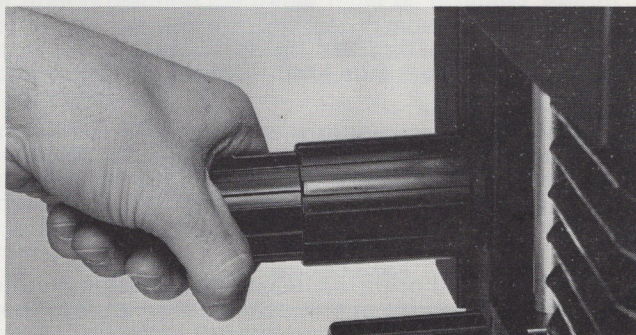

CARRIAGE LOCK CONTROL

A thumb actuated carriage locking lever is provided to further secure the carriage in position on the girder. It is located in front of the carriage module and can be operated from either the left or right side. Place in a vertical position to lock the carriage. Rotating the lever in either direction from the vertical will release the lock.

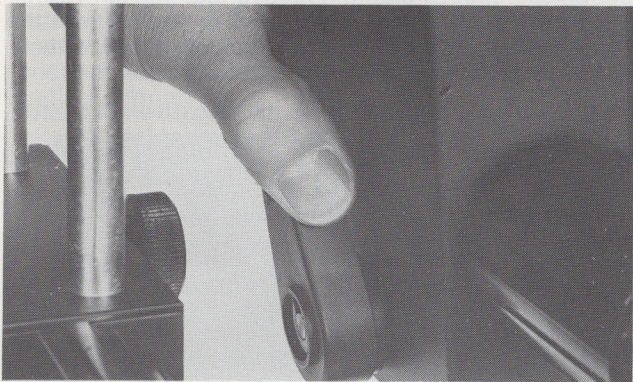

FOCUS CONTROL

Focusing, which controls sharpness, is accomplished by turning either one of two knobs to the right and left of the twin focusing rods, moving the lens up or down on the twin rods.

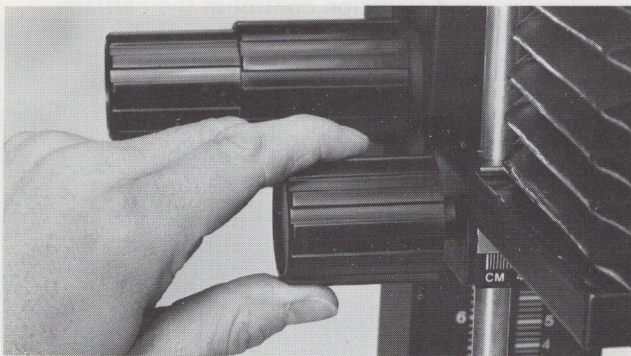

The friction adjusting controls enable you to adjust the tension of the focusing module to your own particular needs. For best results, both controls should be equally adjusted for even tension and smooth and easy movements.

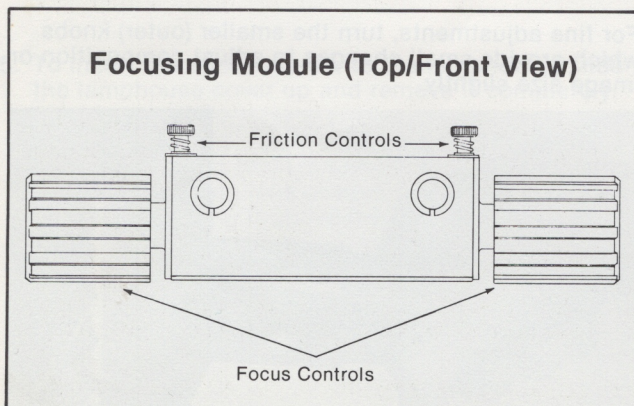

RAPID SHIFT ROTATING NEGATIVE CARRIER

The C760 Enlarger uses a new type of negative carrier. The carrier has one white side which is the upper half, facing the enlarger bulb as the carrier is inserted. Four locating pins on the underside of the carrier position the carrier onto the film stage opening.

1. Place your negative between the guide pins of the carrier and close the plates. Check to see that the entire negative is visible through the negative aperture and that you don't have two halves of two frames on the film strip.

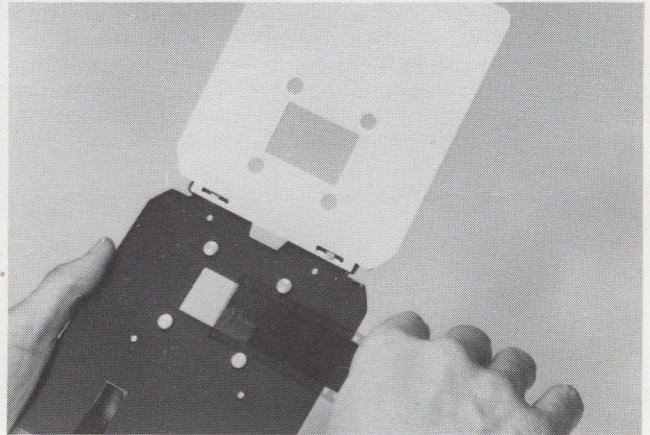

2. The rounded edge of the carrier goes toward the rear of the negative stage, white side up, and is pushed in until the carrier snaps into position. The carrier can be rotated 180° (left or right) to secure the most convenient position of the negative for printing.

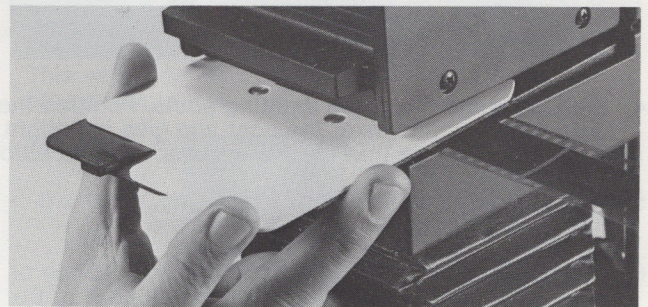

3. To advance the film without removing the negative carrier from the enlarger your carrier is equipped with a unique film release slide which lifts the two plates of the carrier, permitting you to change or move negatives without having to take the carrier out of the enlarger.

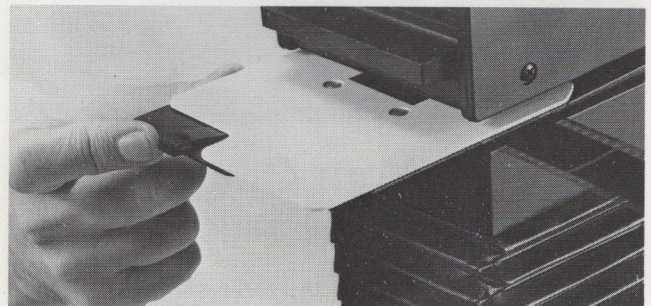

GLASS CARRIER

The C760 Glass Carrier with anit-newton ring glass was specially designed to help keep negatives flat. Because it is twice the thickness of C760 glassless carriers, the C760 Lamphouse must be repositioned prior to using the glass carrier as follows:

1. Loosen lamphouse locking knobs (refer to page 8).
2. Raise the lamphouse and hold it in that position.
3. Insert the glass carrier.
4. Allow the lamphouse to come to rest on the carrier without exerting any additional pressure.
5. Tighten lamphouse locking knobs.

If you switch back to a glassless carrier, be sure to re-adjust the lamphouse accordingly. Refer to pages 8 and 10.

IMAGE DISTORTION CORRECTION CONTROLS

A complete range of image distortion correction controls (swings and tilts) is provided to allow you to either compensate for distortion or to introduce distortion for creative effects. Two stages of control are offered, at the film stage and at the lens stage.

The entire film/lens stage module can be tilted from vertical up to 90° on either side of vertical. To use, loosen the film/lens stage locking knob (located at the right of the carriage module).

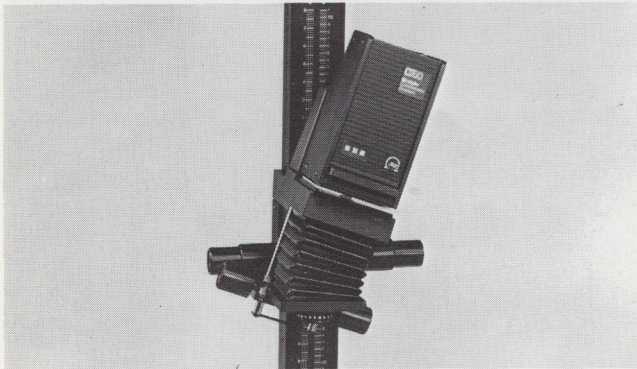

The second stage, at the lens board, involves loosening the lens stage locking knob (located at the rear of the stage between the twin rods) and then manually shifting and tilting the lens board until the desired effect is achieved. The lens stage locking knob is then tightened to keep the lens mount in the desired position.

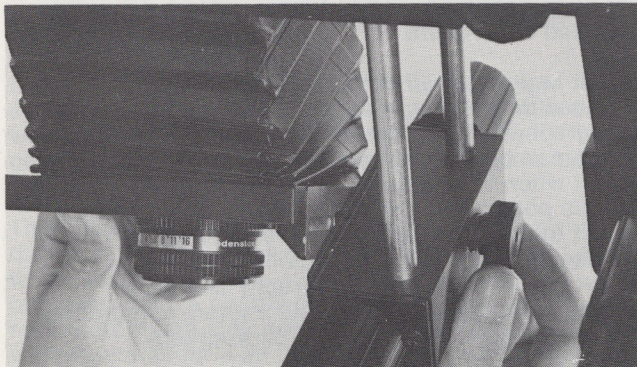

To return the lens mount to "normal" just loosen the lens stage locking knob, bring the lens mount to the "zero detent" position on the lens scale and tighten the knob.

Converging verticals are the result of tilting the camera when taking the picture. If, for instance, you shoot a high building from street level by pointing the camera up towards the sky, the vertical lines will converge in the negative. Such unwanted convergence can be corrected by tilting the enlarger head and the lens stage. To keep the image sharp over all its area with the enlarger head tilted, stop down the lens by two stops or more to increase depth of focus.

This method of distortion control is limited by the depth of focus of the lens and the exposure variation across the image being corrected. With the enlarger head tilted, the projected image is brighter, and hence receives more exposure at one side of the paper. To compensate for this, shade the brighter image area during the exposure.

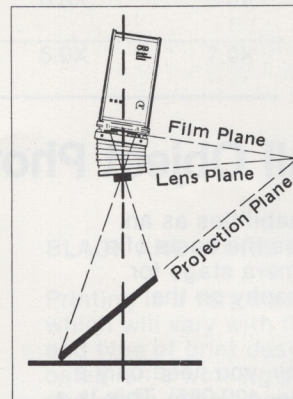

You can correct converging verticals by tilting the enlarger head and the easel. Complete distortion control is also possible by tilting and horizontally displacing the lens stage. As the diagram illustrates, the planes of the film stage, lens stage and easel will converge at some point off the enlarger when complete distortion control is achieved.

When focusing with a 50mm lens at high magnification, the bellows is compressed

leaving little room for tilting the lens stage. As a result the ability to control distortion decreases as the carriage approaches the top of the girder.

The above procedure may also be used to create image distortions for special effects.

FLOOR OR WALL PROJECTION

There may be occasions when the largest magnification available on the baseboard is insufficient for your needs. In this case you have a choice of projecting either on a wall or the floor.

Floor Projection

For floor projection the girder must be reversed. Before starting to reverse your enlarger, remove the lamphouse and film/lens stage modules. You can leave the carriage module on the girder but make sure the carriage is locked into position.

Using the wrench supplied with the enlarger, remove the nuts holding the girder and stabilizing plate and remove the girder from the baseboard. Then, turn the girder around 180°. Remount, using the stabilizing plate and nuts. Make sure to tighten the nuts that support the girder.

Before replacing the lamphouse, place books or similar heavy objects on the baseboard to serve as counterweight, preventing the enlarger from tipping over. Then, replace the negative carrier and lamphouse modules and you are ready to make ultra-large prints.

Wall Projection

For wall projection, the film/lens stage module can be rotated 90° in either direction. Simply loosen the film/lens stage locking knob and rotate module 90°. A positive detent will snap into place. Relock locking knob to secure carriage in place.

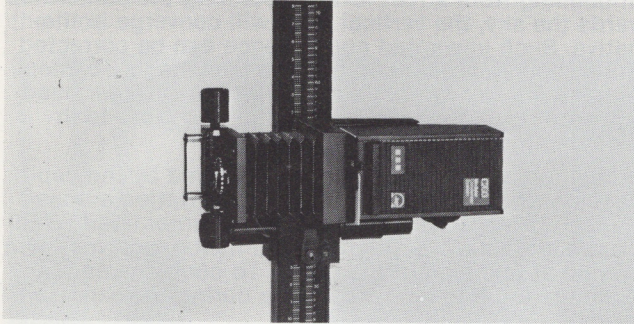

ELECTRICAL CONNECTIONS

The Omega C760 is equipped with a grounded plug which should be used in a suitable outlet (three prong). However, the grounded plug can be used with a two-prong outlet provided a suitable adapter is used.

Standard power requirements for C760 models are: 120V 60 Hz or 240V 50 Hz.

ENLARGING LENSES

One of the most important elements in producing top-quality prints with your C760 Enlarger is a high quality enlarging lens. It is the lens which, ultimately, determines the brilliance and sharpness of your image and you should, therefore, get the best lens you can.

In selecting your enlarging lens, the first consideration is the size of your negative. Consult the magnification reference chart for selection of proper focal length lens.

Copying and Small Object Photography

In addition to its outstanding capabilities as an enlarger, the Omega C760 provides the basis of a convenient, versatile low-cost camera stage for copying and small object photography on the baseboard or other support.

To adapt the C760 for photography, you need only a Copy Camera Attachment (Cat. No. 429-065). This is a grooved post with a 1/4-20 tripod screw on one end and tapered at the other for ease of insertion into the carriage module.

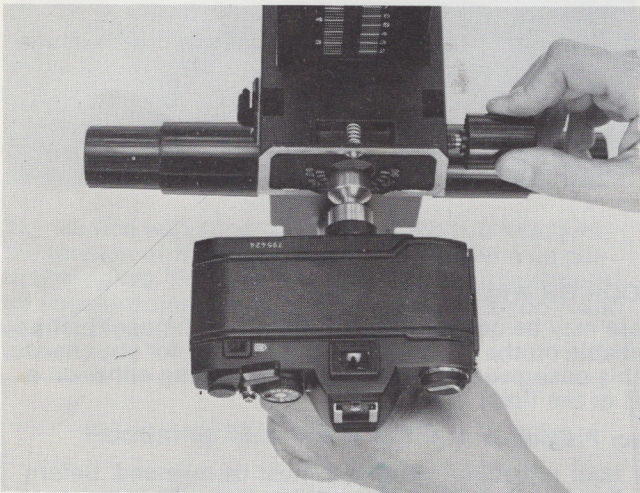

To prepare your enlarger for photography, first put the brake lever in the brake position then remove the lamphouse and film/lens stage module of the C760. Then, screw the Copy Camera Attachment to your camera, making sure your camera is securely fastened. Finally, place camera with attachment into the opening in the carriage module and tighten using the carriage module locking knob.

If you have a Dichroic or Diffusion Lamphouse, you can invert the lamphouse on the baseboard and place slides to be copied directly onto the diffusion screen. Or, you can use the 35mm Mounted Transparency.

Carrier (Cat. No. 423-405) which is then placed on the diffusion screen.

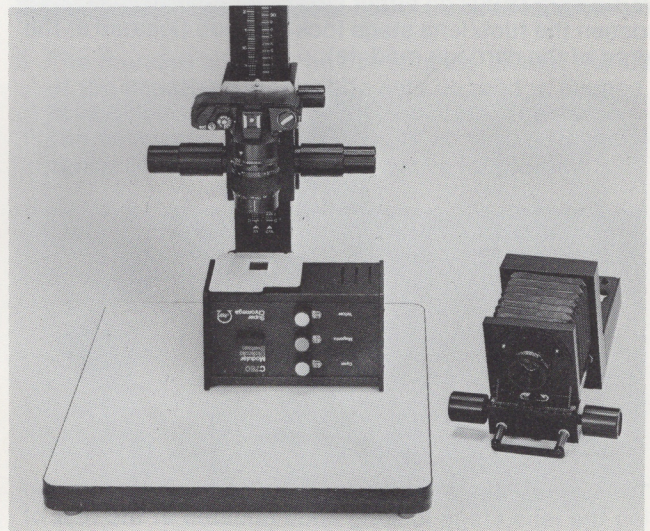

Using the Dichroic Lamphouse for copying color transparencies permits you to correct color rendition or create special effects by dialing the desired filter combination into the lamphouse. This corrects the light illuminating your slide to remove imbalance or unwanted color casts.

For flat copy or small objects photography, items can be placed directly on the baseboard and photographed. When mounted on the C760, your camera can be as close as four inches from your subject when the carriage module is at the lowest possible position on the C760 girder. If your camera will not focus as close as you wish, use either close-up lenses, extension tubes or bellows attachments. For details on close-up photography and proper lighting techniques, consult your camera's instruction book or any good basic text on photography.

It is also possible to photograph objects mounted on walls by turning the camera 90° either left or right.

Omega C760 Magnification Reference Chart

Negative Size	Suggested Focal Length	Minimum Magnification	Maximum Magnification ¹	
			Standard Girder	XL Girder
Minox	25mm	0.17X	28.4X	36.5X
110	35mm	0.2X	19.7X	25.5X
Half Frame 35 3/4x1" (18x24mm)	35mm	0.2X	19.7X	25.5X
35mm 1x1 1/2" (24x36mm)	50mm	0.4X	13.0X	17.2X
6x6cm or 6x4.5cm (2 1/4 x 2 1/4 or 2 1/4 x 1 5/8")	75mm	0.7X	8.0X	10.7X
6x6cm or 6x4 5/8" (2 1/4 x 2 1/4 or 2 1/4 x 1 5/8")	80mm	0.8X	7.3X	10.0X
6x7cm (2 1/4 x 2 3/4")	90mm	1.0X	6.3X	8.6X
6x7cm (2 1/4 x 2 3/4")	105mm	1.4X	5.0X	7.0X

¹All magnifications are based on using an easel with a one-inch height. Maximum print size using a 1" high easel on the baseboard is 16"x20" (40x50cm) using the XL girder and 11"x14" (30x40cm) using the standard girder.

Black and White Printing

This section provides an outline of black and white printing using the Omega C760 Enlarger. For a thorough treatise on all aspects of darkroom work, from developing negatives through color printing and print finishing, the Omega Darkroom Book is highly recommended.

The C760 Systems offers two types of illumination for black and white printing: condensers using the Condenser Lamphouse Module, and diffusion, using either the Diffusion Lamphouse or Dichroic Lamphouse modules. The Dichroic Lamphouse can be used either with the white light lever set so that only diffused light reaches the negative or with the color filters set to provide equivalents of variable contrast filters for black and white papers.

CONDENSER OR DIFFUSION

In actual practice, both types of illumination will produce top-quality prints. However, each type of light has features which may make one more appealing to some photographers than the other.

Condenser illumination provides the most concentrated light and therefore shortest exposure times for any given negative. It also gives more contrast and an impression of increased sharpness as compared with a print from the same negative made using a diffusion lamphouse.

Diffused illumination requires somewhat longer exposures but it produces as sharp a print with a wide range of intermediate tones to maximum contrast. Diffused light also suppresses grain, dust and tiny scratches.

The difference in contrast between condenser and diffusion lighting is equal to about one grade of paper when using a normally exposed and developed negative: thus, a negative which will print satisfactorily on a #2 paper with a condenser system will require about a #3 paper with diffused lighting. This difference in contrast can be corrected for in the initial processing of the film.

BLACK AND WHITE PRINTING HINTS

Printing is a very creative, very personal procedure which will vary with the type of negative, kind of paper and type of print desired. However, you should establish a working pattern for both color and black and white printing so that you become thoroughly familiar with your equipment and materials. Consult the recommended reading list on page 14 for a book on printing in black and white.

CONTROLLING CONTRAST

The simplest way of controlling contrast in black and white printing is through the use of different grades of paper. Papers are generally graded for soft (#1 = least contrasty) to very hard (#4 = extremely contrasty) or ultra hard (#5 = maximum contrast). Most photographers find that a medium (#2) or hard (#3) paper grade will serve for most of their negatives.

For greater convenience and more flexible control, variable contrast paper (such as Kodak Polycontrast®) is available. With this paper, you use filters to change the quality of the light which, in turn, changes the contrast of the print. Variable contrast filters are designated by the same system of contrast grades as papers except that you have intermediate contrasts available. Thus, you have filters ranging from #1, 1 1/2, 2, 2 1/2, 3, 3 1/2 and 4, from soft to very hard.

Variable contrast and other printing filters in plastic frames can be used under the lens. To use filters in this way, you need the Filter Holder (Cat. No. 429-026).

Filters should be protected against dirt and fingerprints which could seriously affect the sharpness of the print. Additionally, you must focus through the filter you are using because many printing filters cause a slight focus shift: an image appearing sharp under unfiltered light will be slightly unsharp when the light is filtered.

Color Printing Hints

The C760 Condenser Lamphouse has a special filter drawer which accommodates 75mmx75mm filters. In this position, the filters affect the light but are out of the image path (lens to paper) so that they do not affect sharpness. This is the preferred placement of filters. The Filter Drawer is an accessory (Cat. No. 429-037).

When using these or any filters, use the accessory Heat Absorbing Glass (Cat. No. 473-118) which is placed between the lamp and the filter to protect the filter from heat. The Heat Absorbing Glass can be left in position at all times. Refer to recommended reading list on this page for color printing procedures.

CONTROLLING CONTRAST DIFFUSION AND DICHROIC LAMPHOUSES

Complete details on controlling contrast of black and white prints when using the C760 Diffusion and Dichroic Lamphouses are given in the special instructions for these units.

Omega C760 Accessories

The following accessories have been designed to increase the usefulness of your Omega C760 enlarger and to handle special needs quickly and conveniently.

Negative Carriers

Nine glassless carriers precision cut for specific negative sizes plus a glass carrier are available. All feature the unique Omega film release slide to permit rapid advance of your film in perfect safety without removing the carrier from the enlarger. Carriers rotate 180° for vertical or horizontal formats.

Cat. No.	Description
423-400	Minox
423-401	110
432-402	126
423-403	35mm Half Frame (18x24mm)
423-404	35mm Full Frame (36x24mm)
423-405	35mm Mounted Transparency
423-406	2 1/4" x 1 5/8" (6x4.5cm)
423-407	2 1/4" x 2 1/4" (6x6cm)
423-408	2 1/4" x 2 3/4" (6x7cm)
423-423	2 1/4" x 2 3/4" (6x7cm) Glass with Anti-Newton Glass

Lens Mounts

421-061	Flat Lens Mount with 39mm Leica thread for all Leica-thread lenses 75mm to 105mm focal length.
421-065	Recessed/Extended Lens Mount. Use "recessed" for Leica-threaded lenses 50mm or shorter. Use "extended" for Leica-threaded lenses for reduction.

Recommended Reading

Probably the best general introduction to good darkroom practice is the **Omega Custom Printmaking Manual**, a concise manual covering film developing, black and white printing and processing.

Other books which are of value include:

There are many other books that cover the art and technique of printing available. The following titles are suggested for more complete information. Books particularly designed for beginners are marked "B".

What is B/W Quality (G-4), Eastman Kodak Co.
Basic Developing, Printing, Enlarging in Color (AE-13) "B", Eastman Kodak Co.
Basic Developing, Printing, Enlarging in Black and White (AJ-2), Eastman Kodak Co.
Bigger and Better Enlarging (AG-19) "B", Eastman Kodak Co.
Kodak Darkroom Dataguide (R-20), Eastman Kodak Co.
The Print: Life Library of Photography "B", Time-Life Books
The Print (Ansel Adams), Morgan & Morgan
The Craft of Photography (David Vestal), Harper & Row
Color Printing (Engdahl), Amphoto
Basic Darkroom, Petersen Publishing
Guide to Creative Darkroom Techniques, Petersen Publishing

Multi-position capability permits mounting lenses so that f/stops face the operator.

Filter Holder

(Cat. No. 429-026)

Swing away holder for use with under-the-lens accessories such as red filter, portrait grid, and other filters, etc.

Copy Camera Attachment

(Cat. No. 429-065)

Permits mounting camera on C760 carriage for copying and photography of small objects on baseboard, etc. Used by simply removing the lamphouse and film stage and replacing modules with camera attached to adapter.

Heavy Duty Wall Mount

(Cat. No. 429-096)

Cast aluminum mount for attaching enlarger girder to wall permitting greater degree of enlargement than is possible with baseboard mounting.

Portrait Diffusion Grid

(Cat. No. 429-012)

A wire-mesh grid mounted under the enlarger lens (using filter holder) to produce softly diffused effects when printing.

Wall Brace

(Cat. No. 429-097)

Special triangular truss metal wall brace provides greater rigidity with table or wall mounted enlarger.

Heat Absorbing Glass

(Cat. No. 473-118)

Provides infrared absorption and heat suppression when used in the C760 Condenser Lamphouse. Recommended for use with printing filters and required for best results when color printing.

Filter Drawer

(Cat. No. 429-037)

For C760 Condenser Lamphouse. Accepts 75mm square gelatin filters used for color, variable contrast, or for special effects printing.

Omega

Omega®

CONTROLLING CONTRAST DIFFUSION AND DICHROIC LAMPHOUSES

Complete details on controlling contrast of black and white prints when using the Omega Diffusion and Dichroic Lamps are given in the special instructions for these units.

Cat. No.	Description
423-400	Mirap
423-401	110
423-402	200
423-403	400
423-404	800
423-405	1600
423-406	3200
423-407	6400
423-408	12800
423-409	25600
423-410	51200
423-411	102400
423-412	204800
423-413	409600
423-414	819200
423-415	1638400
423-416	3276800
423-417	6553600
423-418	13107200
423-419	26214400
423-420	52428800
423-421	104857600
423-422	209715200
423-423	419430400
423-424	838860800
423-425	1677721600
423-426	3355443200
423-427	6710886400
423-428	13421772800
423-429	26843545600
423-430	53687091200
423-431	107374182400
423-432	214748364800
423-433	429496729600
423-434	858993459200
423-435	1717986918400
423-436	3435973836800
423-437	6871947673600
423-438	13743895347200
423-439	27487790694400
423-440	54975581388800
423-441	109951162777600
423-442	219902325555200
423-443	439804651110400
423-444	879609302220800
423-445	1759218604441600
423-446	3518437208883200
423-447	7036874417766400
423-448	14073748835532800
423-449	28147497671065600
423-450	56294995342131200
423-451	112589990684262400
423-452	225179981368524800
423-453	450359962737049600
423-454	900719925474099200
423-455	1801439850948198400
423-456	3602879701896396800
423-457	7205759403792793600
423-458	14411518807585587200
423-459	28823037615171174400
423-460	57646075230342348800
423-461	115292150460684697600
423-462	230584300921369395200
423-463	461168601842738790400
423-464	922337203685477580800
423-465	1844674407370955161600
423-466	3689348814741910323200
423-467	7378697629483820646400
423-468	14757395258967641292800
423-469	29514790517935282585600
423-470	59029581035870565171200
423-471	118059162071741130342400
423-472	236118324143482260684800
423-473	472236648286964521369600
423-474	944473296573929042739200
423-475	1888946593147858085478400
423-476	3777893186295716170956800
423-477	7555786372591432341913600
423-478	15111572745182864683827200
423-479	30223145490365729367654400
423-480	60446290980731458735308800
423-481	120892581961462917470617600
423-482	241785163922925834941235200
423-483	483570327845851669882470400
423-484	967140655691703339764940800
423-485	1934281311383406679529881600
423-486	3868562622766813359059763200
423-487	7737125245533626718119526400
423-488	15474250491067253436239052800
423-489	30948500982134506872478105600
423-490	61897001964269013744956211200
423-491	123794003928538027489912422400
423-492	247588007857076054979824844800
423-493	495176015714152109959648889600
423-494	990352031428304219919397779200
423-495	1980704062856608439838955598400
423-496	3961408125713216879677911196800
423-497	7922816251426433759355822393600
423-498	15845632502852867518711644787200
423-499	31691265005705735037423295574400
423-500	63382530011411470074846591148800

Loss Mounts

421-001	Flat Loss Mount
421-002	Loss Mount with Slits
421-003	Loss Mount with Slits and Holes
421-004	Loss Mount with Slits and Holes and Holes
421-005	Loss Mount with Slits and Holes and Holes and Holes
421-006	Loss Mount with Slits and Holes and Holes and Holes and Holes
421-007	Loss Mount with Slits and Holes and Holes and Holes and Holes and Holes
421-008	Loss Mount with Slits and Holes and Holes and Holes and Holes and Holes and Holes
421-009	Loss Mount with Slits and Holes and Holes and Holes and Holes and Holes and Holes and Holes
421-010	Loss Mount with Slits and Holes and Holes and Holes and Holes and Holes and Holes and Holes and Holes
421-011	Loss Mount with Slits and Holes and Holes and Holes and Holes and Holes and Holes and Holes and Holes and Holes
421-012	Loss Mount with Slits and Holes and Holes and Holes and Holes and Holes and Holes and Holes and Holes and Holes and Holes
421-013	Loss Mount with Slits and Holes and Holes and Holes and Holes and Holes and Holes and Holes and Holes and Holes and Holes and Holes
421-014	Loss Mount with Slits and Holes and Holes and Holes and Holes and Holes and Holes and Holes and Holes and Holes and Holes and Holes and Holes
421-015	Loss Mount with Slits and Holes and Holes and Holes and Holes and Holes and Holes and Holes and Holes and Holes and Holes and Holes and Holes and Holes
421-016	Loss Mount with Slits and Holes and Holes and Holes and Holes and Holes and Holes and Holes and Holes and Holes and Holes and Holes and Holes and Holes and Holes
421-017	Loss Mount with Slits and Holes and Holes and Holes and Holes and Holes and Holes and Holes and Holes and Holes and Holes and Holes and Holes and Holes and Holes and Holes
421-018	Loss Mount with Slits and Holes and Holes and Holes and Holes and Holes and Holes and Holes and Holes and Holes and Holes and Holes and Holes and Holes and Holes and Holes and Holes
421-019	Loss Mount with Slits and Holes and Holes and Holes and Holes and Holes and Holes and Holes and Holes and Holes and Holes and Holes and Holes and Holes and Holes and Holes and Holes and Holes
421-020	Loss Mount with Slits and Holes and Holes and Holes and Holes and Holes and Holes and Holes and Holes and Holes and Holes and Holes and Holes and Holes and Holes and Holes and Holes and Holes and Holes

© 1983 BMC, Division of Berkey Photo, Inc.
Specifications Subject to Change Without Notice

Omega Division
BERKEY MARKETING COMPANIES
25-20 Brooklyn-Queens Expwy. West, Woodside, NY 11377 • (212) 932-4040
3400 East 70th Street, Long Beach, CA 90805 • (213) 774-6405

